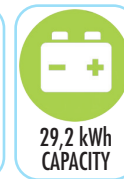
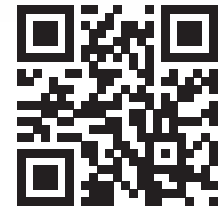
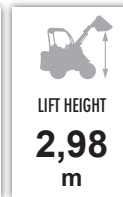
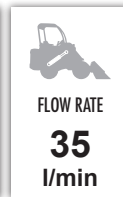
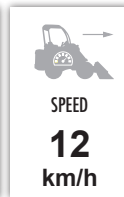
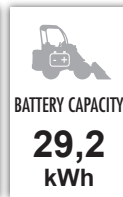

EZ SERIES: EZ8 LONG RANGE

<http://tiny.cc/EZ8seriesEN>**LONG
RANGE**

Model	EZ 8 Long Range
Transmission	Hydrostatic
Drive speed (max.) ⁽¹⁾	12 km/h (7.5 mph)
Aux. hydraulics oil flow	35 l/min (9.3 GPM)
Max. lifting height	2,98 m (117.3 in)
Tipping load, max. ⁽²⁾	1780 kg (3924 lbs)
Lifting capacity straight, max. ⁽³⁾	1420 kg (3130 lbs)
Breakout force / 50 cm	1700 kg (3748 lbs)
Pushing force (c)	2050 kgf (2050 kp)
Average ground pressure (w/standard tires)	958 kg/m ² (196 lbs/sqft)
Turning radius: inside/outside	825/2090 mm (32.5/82.3 in)
Standard tires (Tractor profile)	26X12.00-12 ET-50
Weight	1570 kg (3470 lbs)
Product Code	C963023
EZ8 Long Range Pack 1 (ACI with Multifunction joystick)	C963024

Electric system and battery	
Battery type	LiFePO4
Battery capacity	29,2 kWh
Operation time ⁽⁴⁾ ECO MODE	6 h
Operation time ⁽⁴⁾ POWER MODE	4,5 h
Electric motors	2
Charging system	Integrated charger
Charger type	Sealed single-phase
Charger Input Voltage	110 - 230 ± 10% VAC
Charger Input Frequency	50 ÷ 60 Hz
Charger Absorbed Current	Max. 14 A
Charging Current (230 VAC)	Max. 60 A
Charging Current (120 VAC)	Max. 30 A
Charger plug type	CEE 2P+T
Charger Protection	Output short-circuit, Inverse polarity

⁽¹⁾ Maximum speed that can be achieved with the largest diameter tires available, on a flat surface and machine without attachments.

⁽²⁾ Tipping limit, when the machine is straight, with rear weights and boom lifted just off the ground. Weight of attachment included.

⁽³⁾ Maximum load that can be lifted just off the ground when the machine is straight and with rear weights. Weight of attachment is included.

⁽⁴⁾ The operation time of machine varies highly depending on the type of work it is performing. No hydraulic attachments used.

Note: Refer to the Operator's manual for the comprehensive load diagram.

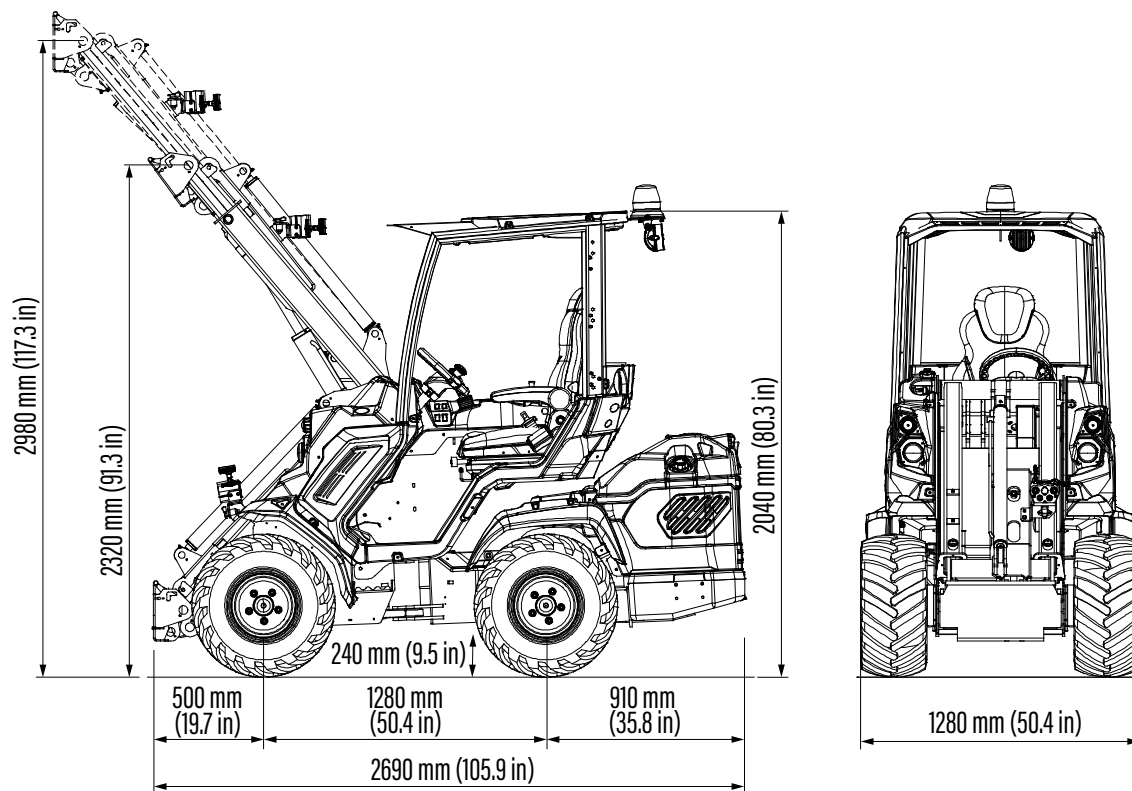

Tires size	Height	Width
23X8.50-12	2020 mm (79.5 in)	1070 mm (42.2 in)
23X10.50-12 ET-25	2020 mm (79.5 in)	1130 mm (44.5 in)
26X12.00-12 ET-50	2040 mm (80.3 in)	1280 mm (50.4 in)
27X8.50-15	2080 mm (81.9 in)	1070 mm (42.1 in)
27X10.50-15	2080 mm (81.9 in)	1150 mm (45.3 in)

FEATURES

- Twin Motors Single Ended Circuits
- LI-ION Battery
- Integrated Smart Battery Charger
- External fast charging station available
- Zero Emission
- Low Noise
- Braking Energy Recovery System
- 4WD hydrostatic Direct Drive motors
- Unbreakable Body Panels
- DBS (Dynamic Block System)
- Self-levelling double-H telescopic boom
- ACI with Multifunction joystick (22 functions) on Pack 1
- Self-locking multi-disk parking brake
- LCD graphic display with programmed service
- 2 front led working lights
- Ergonomic full adjustable suspension seat with armrests and seat belt
- Radial piston high efficiency and heavy duty wheel motors
- Hydraulic multiconnector
- ROPS-FOPS Level I