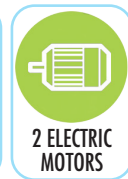
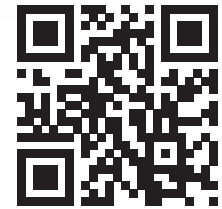
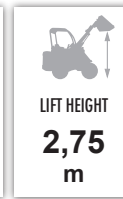
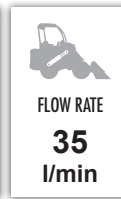
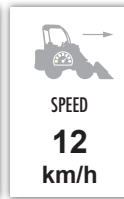
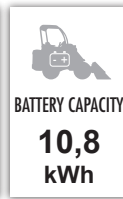

EZ SERIES: EZ5

<http://tiny.cc/EZ5seriesEN>

Model	EZ 5
Transmission	Hydrostatic
Drive speed (max.) ⁽¹⁾	12 km/h (7.5 mph)
Aux. hydraulics oil flow	35 l/min (9.3 GPM)
Max. lifting height	2,75 m (108 in)
Tipping load, max. ⁽²⁾	1110 kg (2447 lbs)
Lifting capacity straight, max. ⁽³⁾	890 kg (1962 lbs)
Breakout force / 50 cm	800 kg (1764 lbs)
Pushing force (c)	900 kgf (900 kp)
Average ground pressure (w/standard tires)	814 kg/m ² (167 lbs/sqft)
Turning radius: inside/outside	800/2000 mm (31.5/78.7 in)
Standard tires (Tractor profile)	23x10.50-12 ET-25
Weight	1020 kg (2250 lbs)
Product Code (Standard)	C977060
EZ5 Pack 1 (ACI with Multifunction joystick)	C977061

Electric system and battery	
Battery type	LiFePO4
Battery capacity	10,8 kWh
Operation time ⁽⁴⁾ ECO MODE	3 h
Operation time ⁽⁴⁾ POWER MODE	2 h
Electric motors	2
Charging system	Integrated charger
Charger type	Sealed single-phase
Charger Input Voltage	110 - 230 ± 10% VAC
Charger Input Frequency	50 ÷ 60 Hz
Charger Absorbed Current	Max. 14 A
Charging Current (230 VAC)	Max. 60 A
Charging Current (120 VAC)	Max. 30 A
Charger plug type	CEE 2P+T
Charger Protection	Output short-circuit, Inverse polarity

⁽¹⁾ Maximum speed that can be achieved with the largest diameter tires available, on a flat surface and machine without attachments.

⁽²⁾ Tipping limit, when the machine is straight, with rear weights and boom lifted just off the ground. Weight of attachment included.

⁽³⁾ Maximum load that can be lifted just off the ground when the machine is straight and with rear weights. Weight of attachment is included.

⁽⁴⁾ The operation time of machine varies highly depending on the type of work it is performing. No hydraulic attachments used.

Note: Refer to the Operator's manual for the comprehensive load diagram.

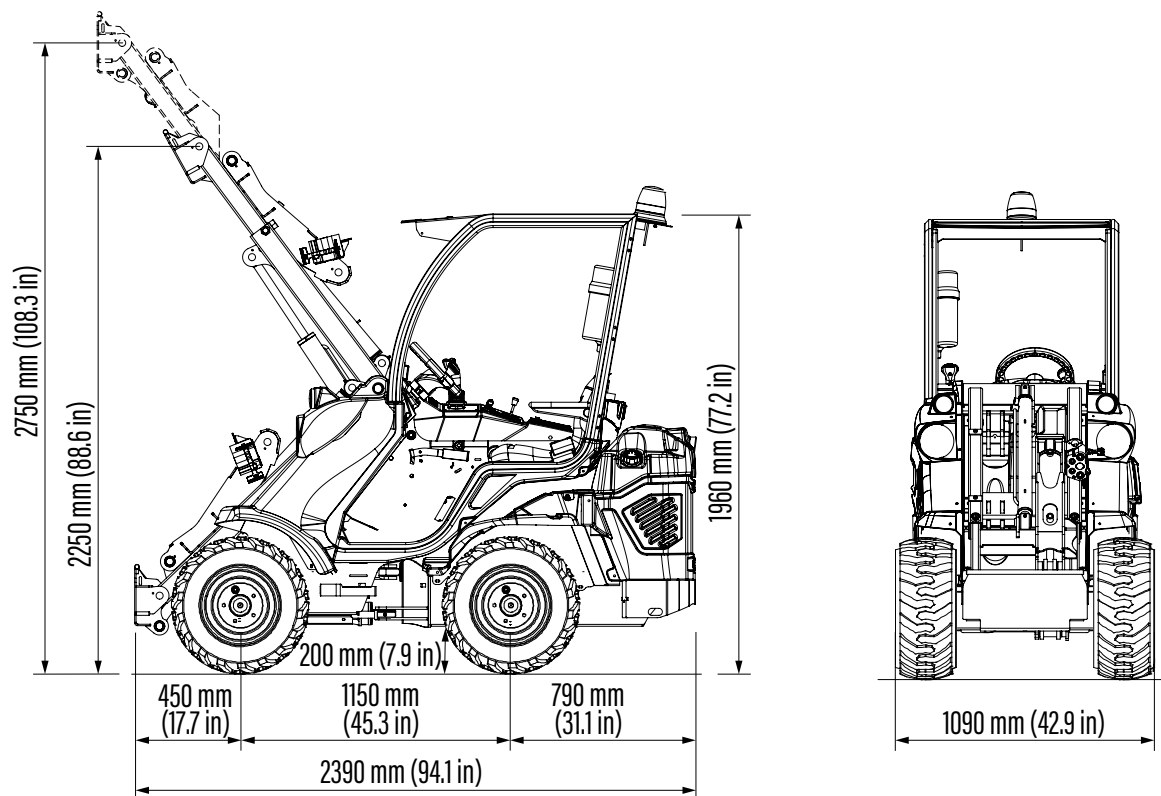

Tires size	Height	Width
23x8.50-12	1960 mm (77.2 in)	980 mm (38.6 in)
23x10.50-12 ET-25	1960 mm (77.2 in)	1090 mm (42.9 in)
27x8.50-15	2010 mm (79.1 in)	1000 mm (39.4 in)
26x12.00-12 ET-50	1998 mm (78.6 in)	1200 mm (47.2 in)

FEATURES

- Twin Motors Single Ended Circuits
- LI-ION Battery
- Integrated Smart Battery Charger
- Zero Emission
- Low Noise
- Braking Energy Recovery System
- Unbreakable Body Panels
- 4WD hydrostatic Direct Drive motors
- DBS (Dynamic Block System)
- Self-levelling double-H telescopic boom
- ACI with Multifunction joystick (22 functions) on Pack 1
- Self-locking parking brake
- LCD graphic display with programmed service
- 2 front led working lights
- Ergonomic full adjustable suspension seat with armrests and seat belt
- High efficiency wheel motors
- Hydraulic multiconnector
- ROPS-FOPS Level I