

5 SERIES: 5.3 K iD

<http://tiny.cc/5series-EN>

ACI
ATTACHMENT
CONTROL
INTERFACE

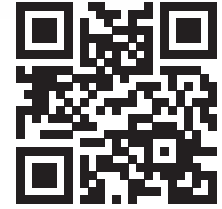
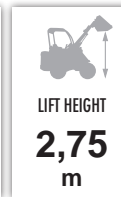
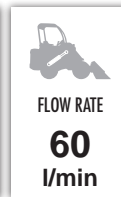
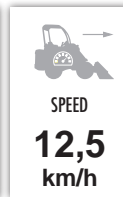
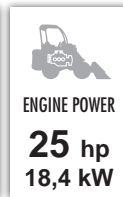

Model	5.3 K iD
Engine	Kubota D1305, 3 cyl. - 1261 cc.
Emission Standard	Stage V
Power (Iso Gross) / Torque	18.4 kW - 25 HP / 85 Nm @ 1700 rpm
Fuel	Diesel
Transmission	Hydrostatic
Drive speed (max.) ⁽¹⁾	12,5 km/h (7.8 mph)
Aux. hydraulics oil flow	60 l/min (15.8 GPM)
Max. lifting height	2,75 m (108 in)
Tipping load, max. ⁽²⁾	1290 kg (2844 lbs)
Lifting capacity straight, max. ⁽³⁾	1030 kg (2270 lbs)
Breakout force / 50 cm (19.7 in)	800 kg (1764 lbs)
Pushing force (c)	900 kgf (900 kp)
Average ground pressure (w/standard tires)	854 kg/m ² (175 lbs/sqft)
Turning radius: inside/outside	800/2000 mm (31.5/78.7 in)
Standard tires (Tractor profile)	23x10.50-12 ET-25
Weight	1070 kg (2360 lbs)
Product Code	C977075

⁽¹⁾ Maximum speed that can be achieved with the largest diameter tires available, on a flat surface and machine without attachments.

⁽²⁾ Tipping limit, when the machine is straight, with rear weights and boom lifted just off the ground. Weight of attachment included.

⁽³⁾ Maximum load that can be lifted just off the ground when the machine is straight and with rear weights. Weight of attachment is included.

Note: Refer to the Operator's manual for the comprehensive load diagram.

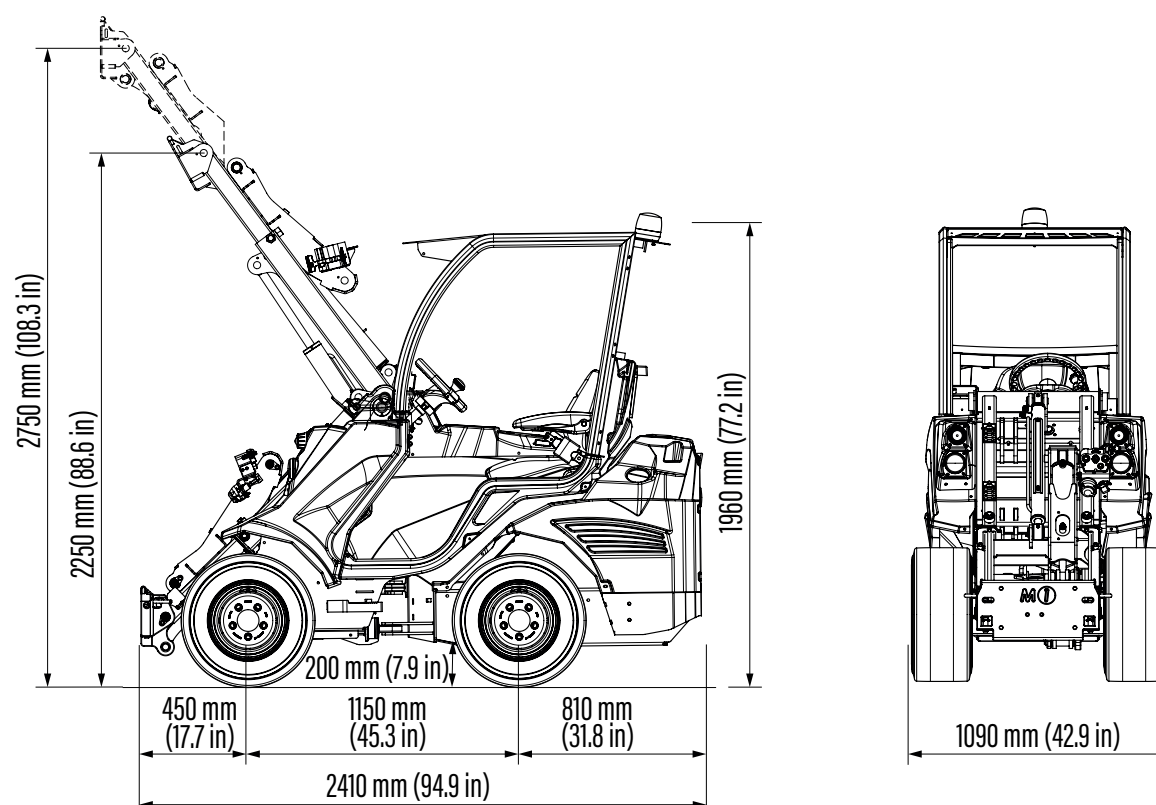

Tires size	Height	Width
23x8.50-12	1960 mm (77.2 in)	980 mm (38.6 in)
23x10.50-12 ET-25	1960 mm (77.2 in)	1090 mm (42.9 in)
27x8.50-15	2010 mm (79.1 in)	1000 mm (39.4 in)
26x12.00-12 ET-50	1998 mm (78.6 in)	1200 mm (47.2 in)

FEATURES

- Kubota D1305, 3 cyl. -1261 cc, diesel engine water cooled, electric start, glow plug
- Stage V compliant engine
- Hi-Flow system
- ACI with Multifunction joystick (22 functions)
- Unbreakable Body Panels
- Self-levelling double-H telescopic boom
- Hydraulically pilot operated variable displacement drive pump
- Dynamic Block System (DBS)
- Hydraulic oil cooler
- Hydraulic multiconnector
- ROPS-FOPS Level I
- LCD graphic display with programmed service
- 4WD hydrostatic Direct Drive motors, proportional servo control
- 2 front working lights
- Ergonomic fully adjustable suspension heated seat with armrests and seat belt
- Mechanical parking brake
- High efficiency wheel motors